



Topic A

Making Like Units Pictorially

5.3H, 5.3K

Focus Standards:	5.3H	Represent and solve addition and subtraction of fractions with unequal denominators referring to the same whole using objects and pictorial models and properties of operations.
	5.3K	Add and subtract positive rational numbers fluently.
Instructional Days:	5	
Coherence -Links from:	G4–M5	Fraction Equivalence, Ordering, and Operations
-Links to:	G5–M4	Multiplication and Division of Fractions and Decimal Fractions
	G6–M3	Rational Numbers

In Topic A, students use the familiar rectangular fraction model to add and subtract fractions with unlike denominators.

Students make like units for all addends or both minuend and subtrahend. First, they draw a wide rectangle and partition it with vertical lines as they would a strip diagram, representing the first fraction with a bracket and shading. They then partition a second congruent rectangle with horizontal lines to show the second fraction. Next, they partition both rectangles with matching lines to create like units.

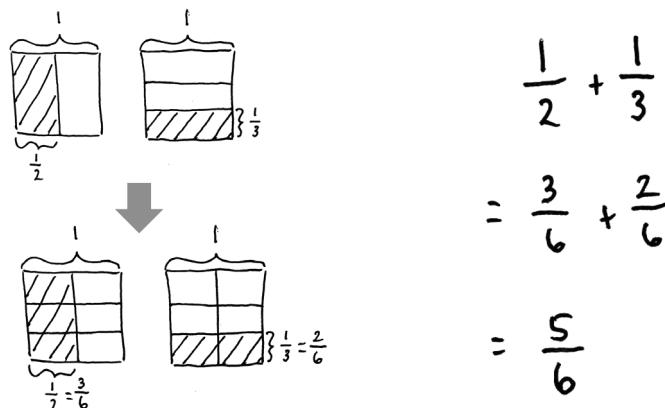

This strategy pictorially proves 3 sixths are equal to 1 half and 2 sixths are equal to 1 third. Students practice making these models extensively until they internalize the process of making like units. Students use the same systematic drawing for addition as they do for subtraction. In this manner, students are prepared to generalize with understanding to multiply the numerator and denominator by the same number. The topic closes with a lesson devoted to solving two-step word problems involving addition and subtraction of fractions.

A Teaching Sequence Toward Mastery of Making Like Units Pictorially

- Objective 1: Add fractions with unlike units using the strategy of creating equivalent fractions.
(Lesson 1)**
- Objective 2: Add fractions with sums between 1 and 2.
(Lesson 2)**
- Objective 3: Subtract fractions with unlike units using the strategy of creating equivalent fractions.
(Lesson 3)**
- Objective 4: Subtract fractions from numbers between 1 and 2.
(Lesson 4)**
- Objective 5: Solve two-step word problems.
(Lesson 5)**